

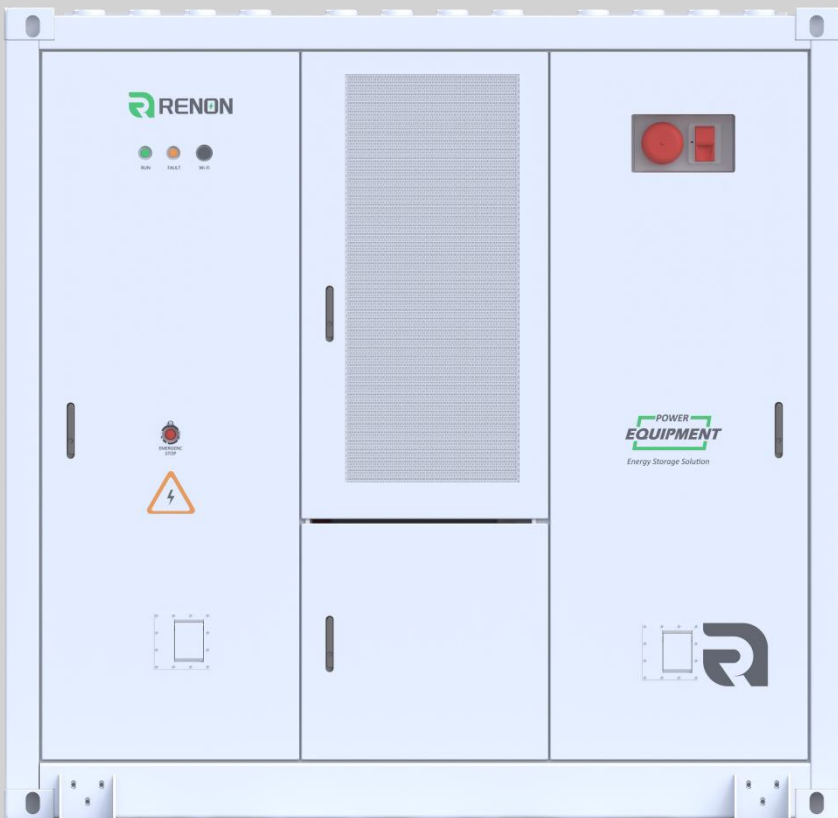

Installation Manual

R-SM1672860A1-US

Smart Matrix A



○ E-mail: support@renon-usa.com

Buyer:

Supplier:

2025 1ST EDITION

© Renon Power USA LLC.
All rights reserved. Specifications are subject to change without notice.

Renon Power

We Care About Sustainability

With our own R&D team and automatic production factory, we are dedicated to delivering innovative, reliable, and affordable energy storage solutions to global customers.

At Renon, we believe that sustainable energy is the future. We are passionate about reducing carbon emissions and preserving our planet for future generations. That's why we invest heavily in research and development, leveraging the latest technologies to design and manufacture energy storage systems that are efficient, scalable, and adaptable.

Our products are designed to meet the needs of a wide range of applications, from residential and commercial buildings to industrial facilities and utility-scale projects. Whether you're looking to reduce your energy bills, increase your energy independence, or support your sustainability goals, Renon has the right solution for you.

Our commitment to quality and customer satisfaction is unwavering. We work closely with our clients to understand their unique needs and provide customized solutions that meet or exceed their expectations. We also provide comprehensive technical support, maintenance, and warranty services to ensure that our customers get the most out of their investment.

[Join us on our mission to make renewable energy within reach.](#)

PROVIDE **INNOVATIVE,**
RELIABLE, AND
AFFORDABLE ENERGY
STORAGE SOLUTIONS
TO CUSTOMERS
WORLDWIDE.



CONTENTS

1. PREFACE	- 1 -
1.1. APPLICABLE PRODUCTS	- 1 -
1.2. APPLICABLE AUDIENCE	- 1 -
1.3. SYMBOL DEFINITIONS	- 1 -
2. SAFETY PRECAUTIONS	- 2 -
2.1. GENERAL SECURITY	- 2 -
2.2. SYSTEM SAFETY	- 2 -
2.3. LABEL INSTRUCTIONS	- 3 -
2.4. BATTERY SAFETY	- 4 -
2.5. PERSONNEL REQUIREMENTS	- 4 -
3. PRODUCT PROFILE	- 5 -
3.1. APPEARANCE OVERVIEW	- 5 -
3.2. DIMENSION	- 6 -
3.3. COMPOSITION	- 6 -
3.4. COMMUNICATION POWER DISTRIBUTION PANEL	- 7 -
4. STRUCTURE FIXATION AND INSTALLATION	- 8 -
4.1. SPACE REQUIREMENTS	- 8 -
4.2. CABLE ENTRY ILLUSTRATION	- 9 -
4.3. FOUNDATION REQUIREMENTS	- 10 -
4.4. HANDLING REQUIREMENTS	- 11 -

4.4.1. Crane Transport - 11 -

5. ELECTRICAL CONNECTION - 12 -

5.1. ELECTRICAL WIRING DIAGRAM - 12 -

5.2. PRE-WIRING PREPARATION - 13 -

 5.2.1. Tool Preparation - 13 -

 5.2.2. Cable Preparation - 14 -

5.3. GROUNDING CABLE CONNECTION - 14 -

5.4. AC POWER CABLE CONNECTION - 15 -

5.5. AUXILIARY POWER SUPPLY CABLE CONNECTION - 16 -

5.6. COMMUNICATION CABLE CONNECTION (RESERVED) - 16 -

 5.6.1. IES - 16 -

 5.6.2. Communication Terminal block XT1 - 17 -

6. POWER-ON/POWER-OFF PROCEDURE - 18 -

6.1. CHECK BEFORE POWER ON - 18 -

6.2. POWER ON - 19 -

6.3. POWER OFF - 20 -

6.4. EQUIPMENT DOOR-CLOSE - 20 -

7. REVISION TABLE - 21 -

1. Preface

This manual primarily covers the product information, installation instruction and power-on/off procedures. Before installing and using this product, it is imperative to thoroughly read this manual. Doing so will ensure your understanding of the safety information and acquaint you with the features and characteristics of the product.

1.1. Applicable Products

This manual applies to the **Smart Matrix A**. The product models include:

No.	Configuration	Product Model
1	Smart Matrix A	R-SM1672860A1-US

1.2. Applicable Audience

This manual is intended for professional personnel who are familiar with local regulations and standards, have undergone specialized training, and possess a thorough knowledge of this product.

1.3. Symbol Definitions

For better use of this manual, the following symbols are used to highlight important information. Please read the symbols and instructions carefully.

Danger
Indicates a high potential for danger. Failure to avoid this hazard could result in death or serious injury.
Warning
Indicates a moderate potential for danger. Failure to avoid this hazard could result in death or serious injury.
Caution
Indicates a low potential for danger. Failure to avoid this hazard could result in moderate or minor injury.
Note
Indicates an emphasis or supplement to the content. It may also provide tips or tricks for optimizing the use of the product, helping you resolve issues or save time.

2. Safety Precautions

When operating the equipment, it is imperative to comply with all safety precautions contained herein.

Note
The equipment has been designed in strict accordance with the safety regulations and qualified for the test, but as electrical equipment, the relevant safety instructions shall be observed before any operation of the equipment, and any improper operation may lead to serious injury or property loss.

2.1. General Security

Note
<ul style="list-style-type: none"> ● This manual may be updated periodically due to product upgrades or other reasons. This manual does not take precedence over, and shall not be used to override, the safety warnings and precautions printed on the product labels. All information herein is provided for guidance only and does not constitute a warranty of any kind. ● Carefully read this manual before installing the equipment to understand the product and relevant precautions. ● All operations on the equipment must be performed by qualified electrical technicians who are familiar with the relevant standards and safety regulations applicable to the project location. ● When working on the equipment, always use insulated tools and wear appropriate personal protective equipment (PPE). When handling electronic components or internal assemblies, additional anti-static measures (such as gloves, wrist straps, and clothing) must be taken to prevent electrostatic discharge (ESD) damage. ● The manufacturer is not responsible for equipment damage or personal injury caused by failing to install, use, or configure the equipment according to this manual or the corresponding user manual. For more information on product warranties, please visit the official website.

2.2. System Safety

Danger
<ul style="list-style-type: none"> ● Always observe all safety precautions and warnings contained in this manual, any accompanying documentation, and on the product labels. ● Strictly comply with all local laws, regulations, and industry standards when operating the equipment. ● Transportation & Handling: Ensure transport personnel are professionally trained. During loading, unloading, and movement, use appropriate equipment and follow procedures to maintain balance and prevent drops. Avoid rough handling, as impacts can damage the battery racks, potentially causing short circuits, electrolyte leakage, fire, or explosion. Comply with all local regulations and industry standards for handling heavy equipment. ● This is heavy equipment. Always use suitable lifting tools and take all necessary protective measures during installation and maintenance to prevent personal injury or equipment damage. ● The equipment contains lethal high voltage. Never touch any internal or external conductive parts unless power is confirmed off and locked out. ● Only trained and authorized professionals may open battery rack doors or access internal components. ● Do not operate the equipment if it is damaged, faulty, or indicates an alarm (including ground fault alarms). An active alarm does not guarantee the absence of hazardous voltage. Operating faulty equipment increases the risk of electric shock and fire. ● Before any work, ensure the system is properly grounded and that all required safety measures

- (lockout/tagout) are in place.
- The system must be properly grounded upon installation. Before performing any operation, verify that all safety measures are in place to prevent electric shock.







Warning

- Do not strike, pull, drag, or step on the equipment. Do not pierce the equipment casing with sharp objects.
- Do not place any unrelated objects inside the battery racks.
- The equipment is equipped with an automatic fire suppression system. Activate the manual suppression switch ONLY in case of fire emergency.
- All cables must comply with local electrical codes and regulations.
- The voltage and frequency at the grid connection point MUST meet the specifications specified for the battery racks.
- Circuit breakers or fuses MUST be installed on the AC side of the equipment as overcurrent protection devices.
- Do not install the equipment in high-temperature environments or near heat sources.

Danger

After installation, ensure that the labels and warning signs on the battery racks are clearly visible. Do not obstruct, deface, or damage them .

2.3. Label Instructions

	<p>High voltage danger. There is high pressure during the equipment. When operating the equipment, make sure the equipment is powered off.</p>		<p>Potential hazard after equipment operation. When operating, please protect yourself.</p>
	<p>There is high temperature on the surface of the equipment, no touch when the equipment is running, otherwise it may cause scald.</p>		<p>Protect the ground wire connection point.</p>
	<p>Battery recycling: the equipment should not be treated as household waste. Please treat the equipment according to local laws and regulations, or send it back to the equipment manufacturer.</p>		<p>System recycling: the equipment should not be treated as household waste, please treat the equipment according to the local laws and regulations.</p>

2.4. Battery Safety

Warning

If the battery leaks electrolyte, avoid contact with the leaked liquid or gas. Electrolyte is corrosive and can cause skin irritation and chemical burns. If contact occurs, follow these steps:

- Eye Contact: Rinse eyes with water for at least 15 minutes and seek medical assistance immediately.
- Skin Contact: Wash the affected area thoroughly with soap and water and seek medical assistance immediately.
- Inhalation: Move away from the contaminated area and seek medical assistance immediately.
- Ingestion: Induce vomiting and seek immediate medical attention.

Warning

- A burning battery may release toxic and harmful gases.
- In the event of a fire, immediately call the fire department and notify firefighters, providing them with relevant product information.
- If safe to do so, disconnect the power supply to the equipment by turning off the upstream and downstream switches.

2.5. Personnel Requirements

Note

- Personnel responsible for the installation and maintenance of the equipment must undergo rigorous training to understand all safety precautions and master the correct operating procedure.
- Installation, operation, maintenance, and replacement of the equipment or its Instructions s should only be performed by qualified professionals or trained personnel.

3. Product Profile

3.1. Appearance Overview

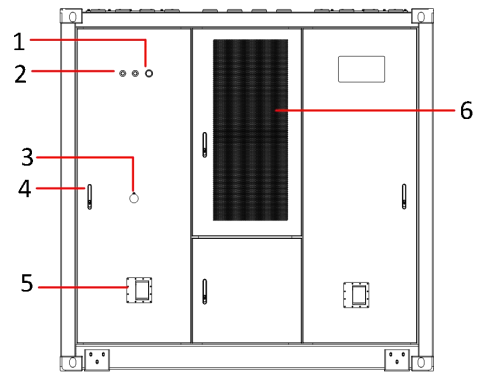
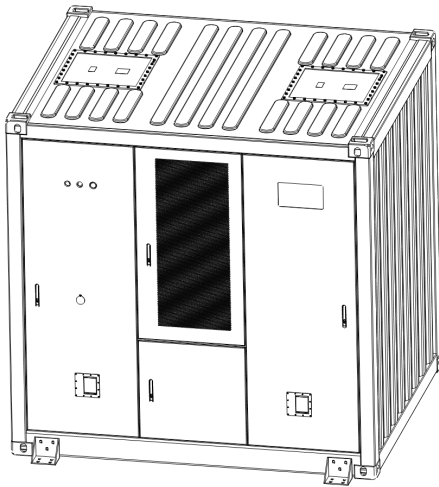

Front View

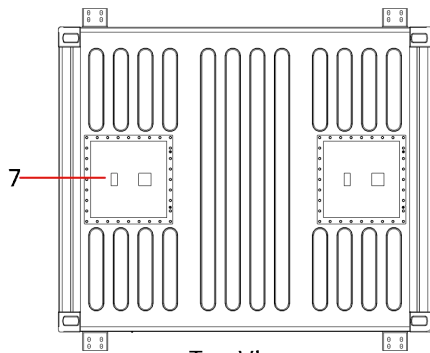

Top View

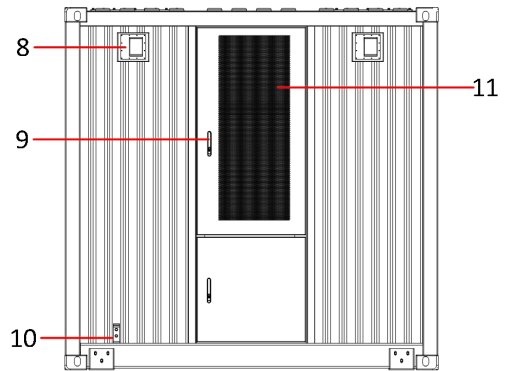

Back View

No.	Component	No.	Component
1	4G/WIFI	2	Indicator Light (RUN/FAULT)
3	Emergency Stop Button	4	Front Door Lock
5	Intake Fan	6	Air Intake
7	Explosion Vent	8	Exhaust Fan
9	Back Door lock	10	Grounding Terminal
11	Air Outlet		

3.2. Dimension

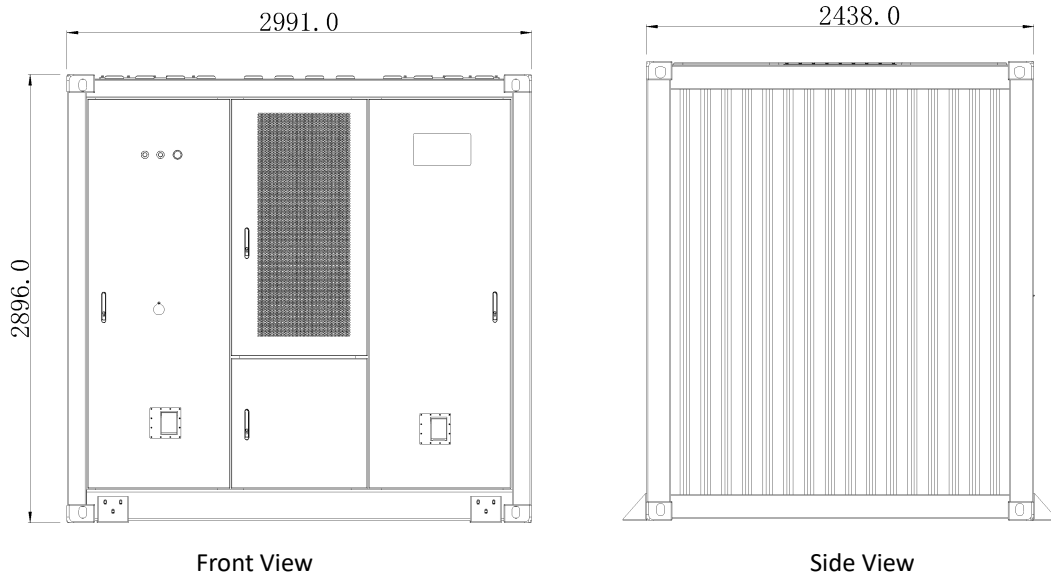

No.	Project	Parameters
1	Dimension (W*D*H)	2991 x 2438 x 2896 mm(±10mm)
2	Weight (Net Weight)	33069 lb (15T) ²

*Weight is for reference only and subject to the actual product.

3.3. Composition

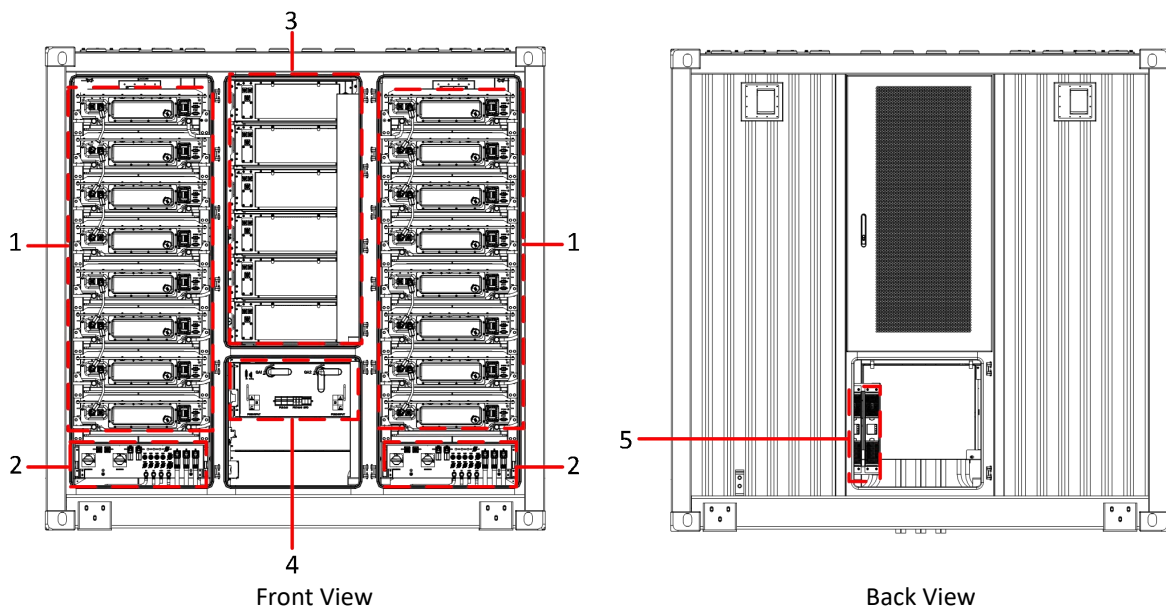

No.	Component	No.	Component
1	Battery Module	2	Power Conversion System (PCS)
3	Chiller	4	Combiner Box
5	Uninterruptible Power Supply (UPS)		

3.4. Communication Power Distribution Panel

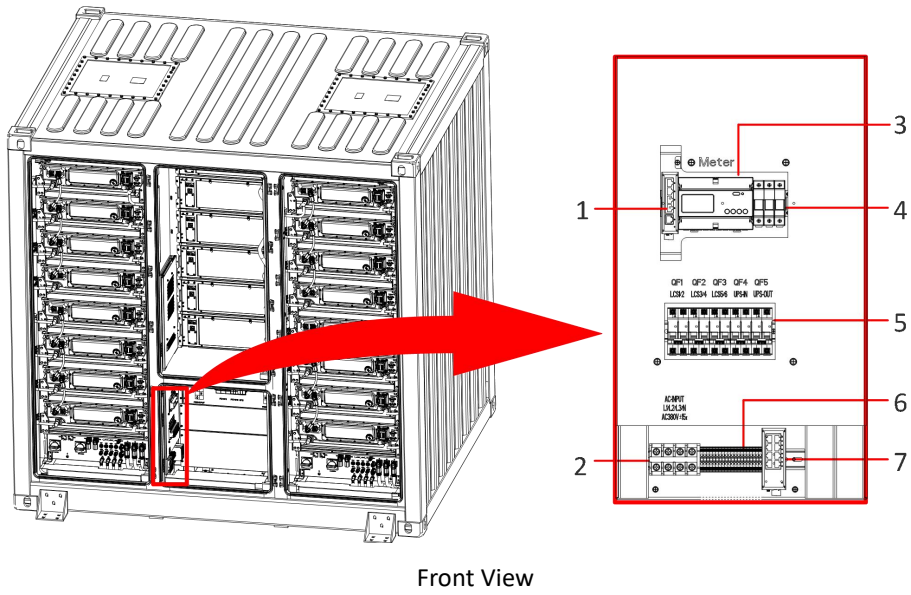

No.	Component	Remark
1	Industrial Ethernet Switch	IES #2
2	Meter	
3	Auxiliary Power Input Terminal Block	XTAC
4	Fuse	
5	Circuit Breakers	QF1~5
6	Communication Terminal Block	XT1
7	Industrial Ethernet Switch	IES #1

4. Structure Fixation and Installation

4.1. Space Requirements

To ensure proper ventilation and maintenance access for the Smart Matrix A, sufficient clearance must be provided around the installation site. The diagram below illustrates the airflow (intake/exhaust) and minimum space requirements.

- **Airflow Intake & Exhaust Illustration:** Keep at least 39.4in(1000mm) of clearance in front of and behind the cabinet.
- **Maintenance Space:** A minimum 157.5in (4000mm) front clearance is required to provide enough space for installation and maintenance. If the Smart Matrix A can be lifted to an open area for maintenance , reduction of the space is permitted accordingly.
- **Door Operation:** The maximum door opening angle is 110°. After opening, remember to fasten the windproof hook.

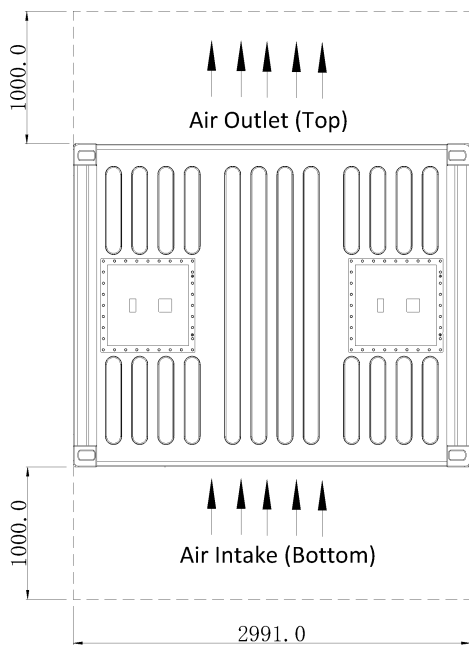

✔ Airflow Intake & Exhaust Illustration (Top View)

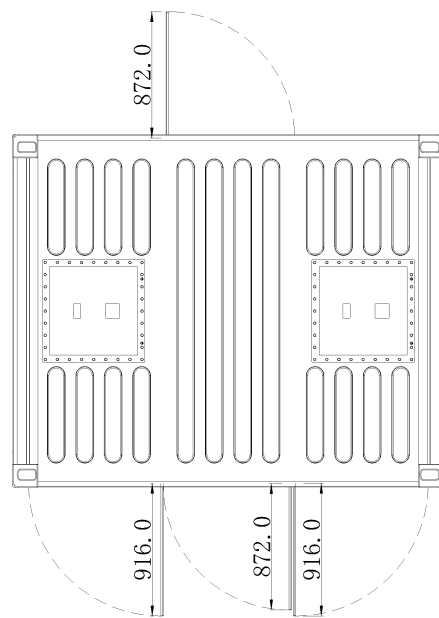

✔ Door Operation Diagram (Top View)

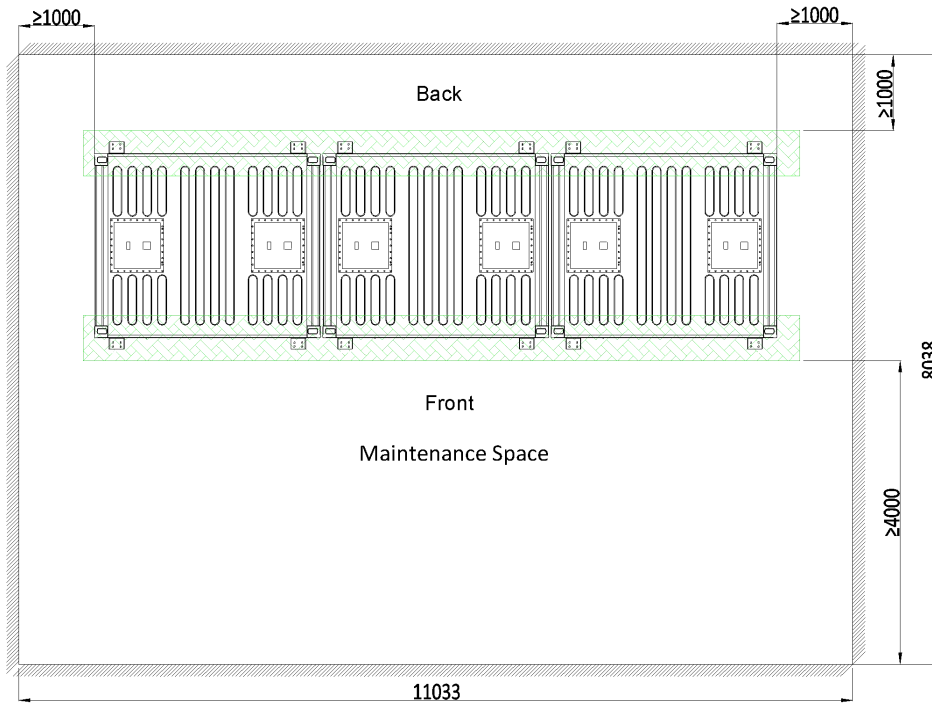

✓ Maintenance Space (Top View)

4.2. Cable Entry Illustration

The following diagram shows the bottom cable entries and the pre-embedded conduits, which are outlined in red.

- Cable Entry: Cable entry#1 is used for AC power cable entry; cable entry#2 is used for auxiliary power supply cable and communication cable entry;
- Cable Route: The user may employ either pre-embedded conduits or cable trenches to reserve the cable pathway. The exact routing shall be determined by the user; this diagram is for layout reference only.

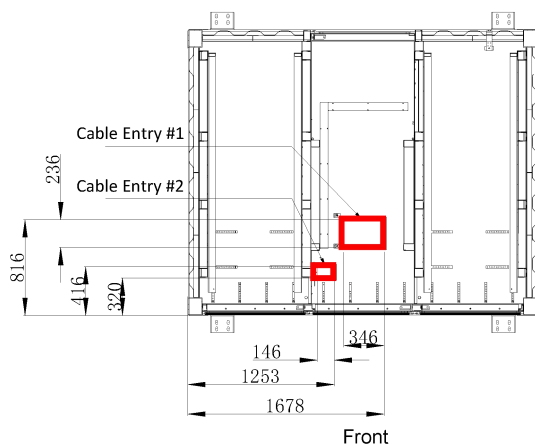

✓ Cable Entry (Top View Inside the Cabinet)

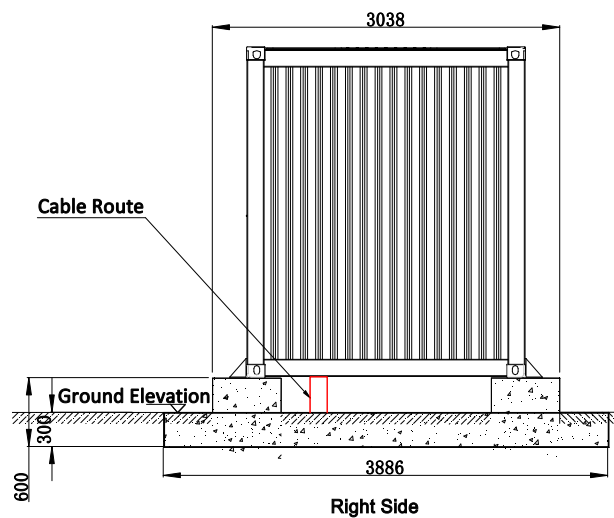

✓ Cable Route Diagram (Right Side View)

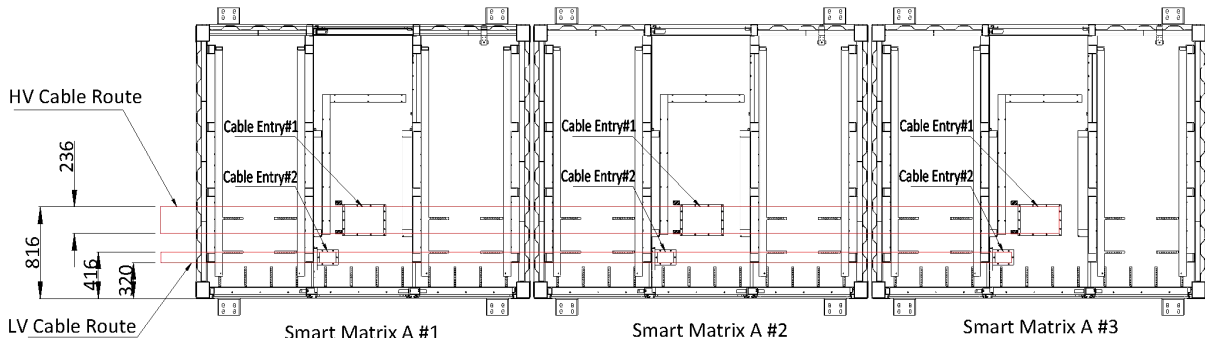

✓ Cable Route Diagram (Top View)

4.3. Foundation Requirements

The following table and diagram specify the requirements for concrete foundation and sub-base.

Notice		
1	Excavation & Soil Compaction	<ul style="list-style-type: none"> ➤ During foundation excavation, the subgrade soil must be properly compacted. ➤ Loose, wet, or organic soils require ground improvement (e.g., soil replacement). ➤ The foundation shall be sited at the highest local elevation to prevent water accumulation.
2	Materials	<ul style="list-style-type: none"> ➤ Primary Foundation: 11.8in(300mm) thick, C30 structural reinforced concrete. ➤ Base Layer: 11.8in(300mm) of C15 lean concrete.
3	Flatness	<ul style="list-style-type: none"> ➤ Level the foundation surface and ensure its surface is within 0.2in(5mm) of the floor level.
4	Load Distribution	<ul style="list-style-type: none"> ➤ The concrete pedestal must be level and have a smooth surface to ensure uniform load distribution for the product's total weight.
5	General Notes	<ul style="list-style-type: none"> ➤ This diagram is for schematic guidance only. The final design must comply with local codes and site conditions. ➤ Fireproofing: After installation, seal all cable outlets with fireproof putty.

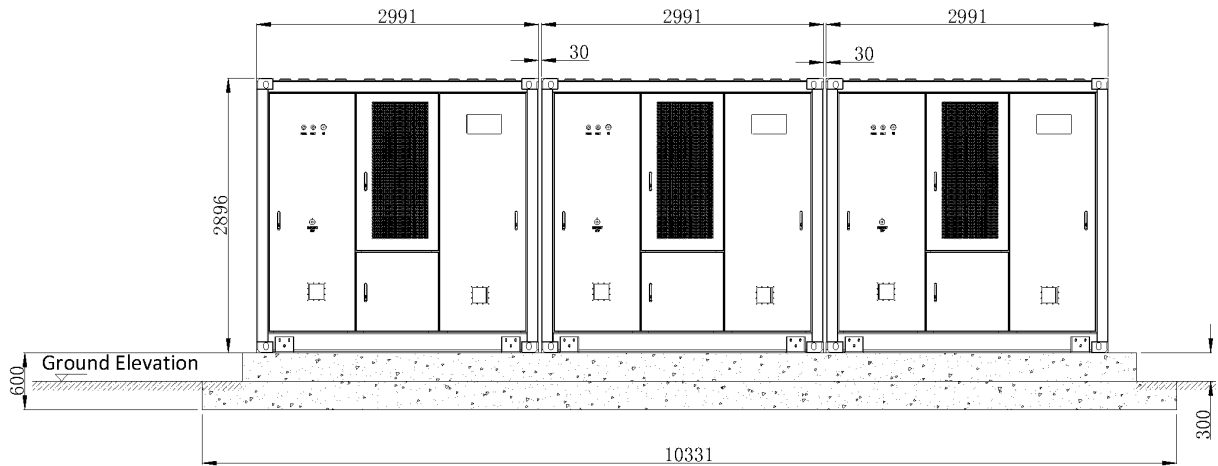

✓ Foundation Requirements (Front View)

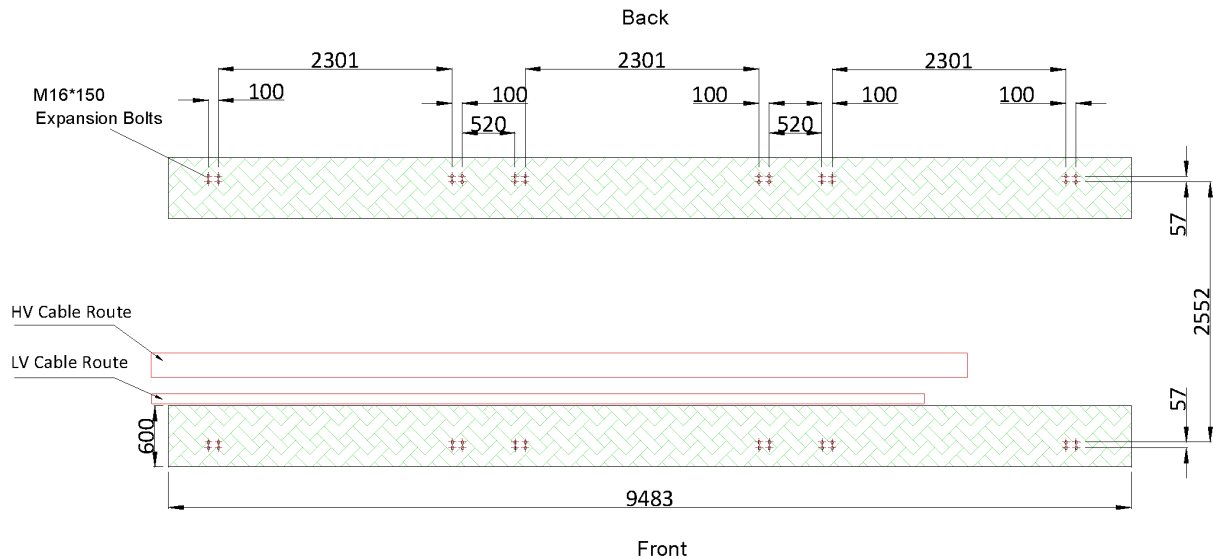

Installation Location Diagram for 3 Smart Matrix A (Top View)

4.4. Handling Requirements

Note	
➤	During all ESS lifting operations, strict adherence to safe lifting practices is mandatory. Personnel are prohibited from standing under the container or within the crane's operating radius.
➤	Lifting must cease immediately in adverse weather conditions, including rain, fog, or strong winds.

4.4.1. Crane Transport

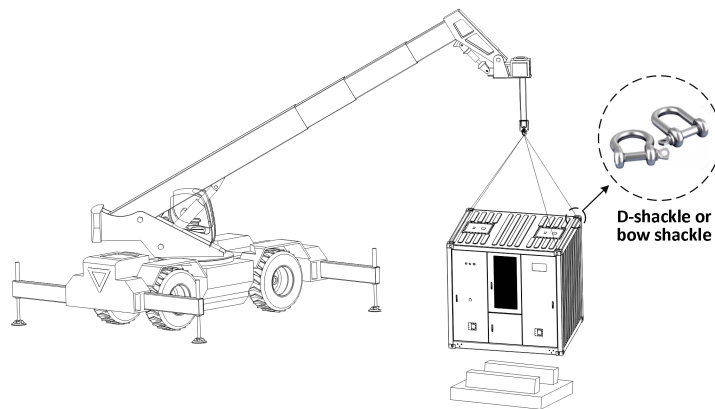

- **Crane Selection:** Select a crane with a minimum rated capacity of 55,116lb (25,000kg) The lift must be configured using four independent lifting slings, each with a minimum load capacity of 17,637lb (8,000kg).
- **Lifting Point Preparation:** The Smart Matrix A is equipped with corner fittings on all four top corners. Prepare D-shackles or bow shackles rated for 17,637lb (8,000kg) to connect the slings to these fittings.
- **Pre-Lift Inspection:** Prior to lifting, inspect all connections of the lifting gear to ensure they are secure and properly engaged. Lifting may commence only after confirming that all connections are tight.
- **Lifting Procedure:** The equipment must be lifted vertically. Dragging it on the ground or pushing against any surface is strictly prohibited. Throughout the lift, proceed at a slow, controlled speed while continuously monitoring the container's balance. Avoid any sudden or rapid movements.

5. Electrical connection

Danger

- Do not touch live parts.
- Before wiring, ensure the polarity of all input cables is correct for each circuit.
- Never pull cables or wires forcefully to prevent insulation damage.
- Ensure all cables/wires have sufficient bending space/flexibility to avoid strain.
- Use strain relief measures (e.g., ties) to minimize mechanical stress on cables.
- After each wiring step, inspect connections to ensure they are secure and correctly installed.

5.1. Electrical Wiring Diagram

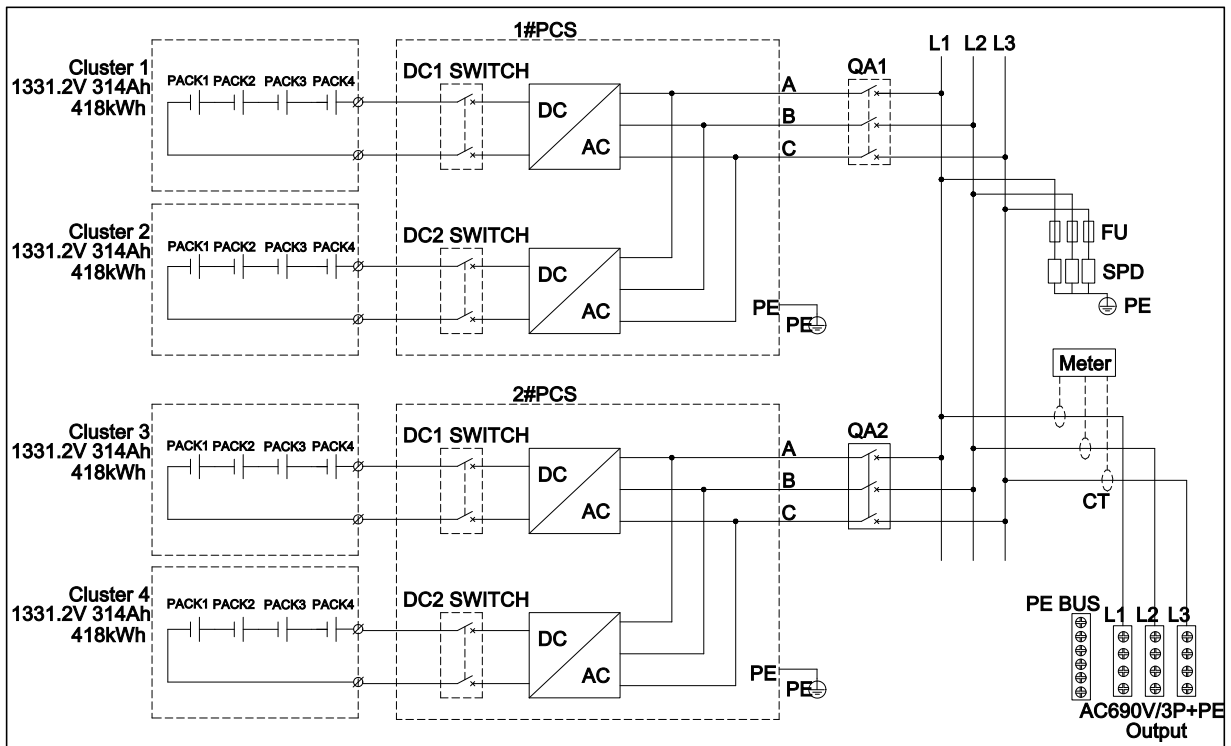

Danger

















- All electrical connections must be strictly made in accordance with the wiring diagram
- All electrical connections must be performed only when the equipment is completely de-energized.

5.2. Pre-Wiring Preparation



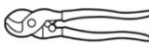

5.2.1. Tool Preparation

Prior to installation, prepare all necessary installation tools (e.g., insulated socket wrenches, screwdrivers) and personal protective equipment (PPE). All tools used must be of an insulated type.

(1) Installation tools

Type	Tools and Instruments		
Installation Tools	 Crimping Pliers	 Socket Torque Wrench	 Impact Drill
	 Torque Wrench	 Diagonal Cutting Pliers	 Wire Stripping Pliers
	 Hot Air Gun	 Vacuum Cleaner	 Marker Pen
	 Level	 Heat Shrink Tubing	 Cable Ties
	 Multimeter	 Rubber Mallet	 Steel Tape Measure
	 Utility Knife	 Lineman's Pliers	 Torque Screwdriver

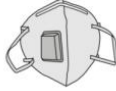
(2) Personal Protective Equipment (PPE)

Type	Tools and Instruments		
PPE	 Goggles	 Safety Shoes	 Safety Gloves
	 Dust Mask	 Insulating Gloves	

5.2.2. Cable Preparation

	Cable Type		Section	Remark
Smart Matrix A	Grounding Cable	Protective Grounding	Section 5.3	User-supplied
		Functional Grounding		User-supplied
	AC Power Cable		Section 5.4	User-supplied
	Auxiliary Power Supply Cable		Section 5.5	User-supplied
	Communication Cable (Reserved)		Section 5.6	User-supplied

Note

- The cable specifications and colors depicted in this manual are for guidance only. Users shall select cables that comply with local codes and regulations. The recommended conductor cross-sectional areas are provided in the specifications below.
- Selected cables must:
 - ① Be properly sized to carry the maximum expected current with adequate ampacity;
 - ② Include sufficient length allowance for routing and termination;
 - ③ Be flame-retardant (preferred).

5.3. Grounding Cable Connection

Connect the following to the grounding electrode (e.g., ground rod or grounding grid):

- Functional Grounding
- Protective Grounding

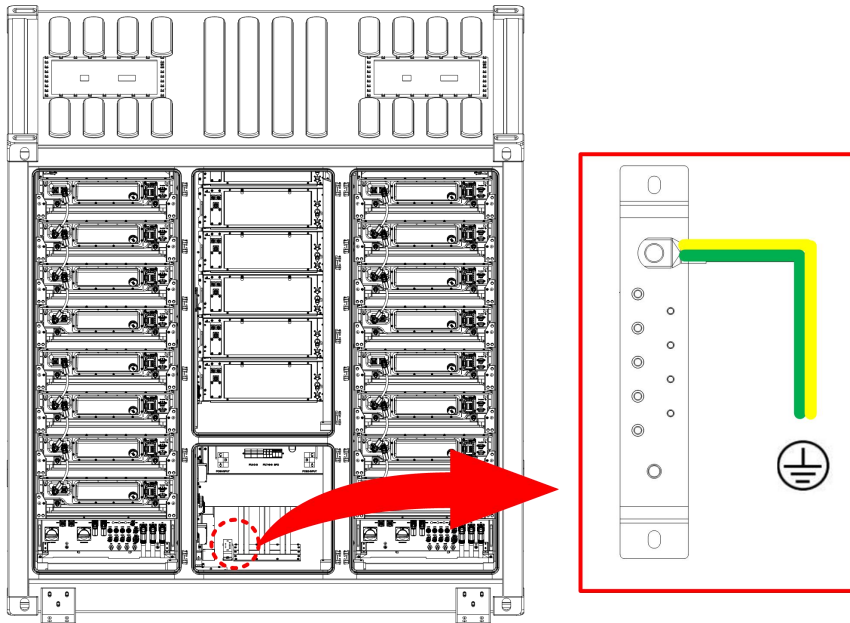

✔ Functional Grounding : Smart Matrix A (Front View)

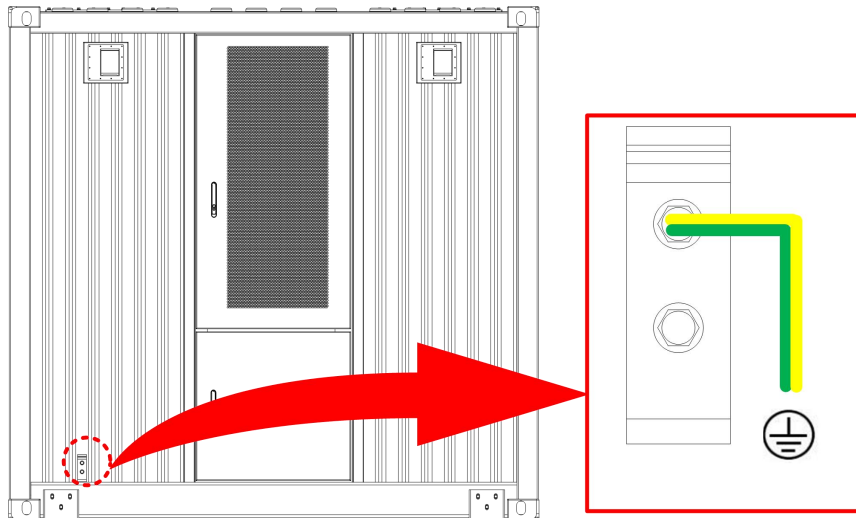

✔ Protective Grounding: Smart Matrix A (Back View)

No.	Name	Functional Grounding	Protective Grounding
1	Recommended Cable		150mm ² (300Kcmi) Rated Voltage: AC 1000V min Rated Temperature: 105°C min
2	Connection terminal		SC150-12 (Torque: 47N·m)

5.4. AC Power Cable Connection

Connect the power cable from the Smart Matrix A to Grid or AC Combiner Unit or Grid.

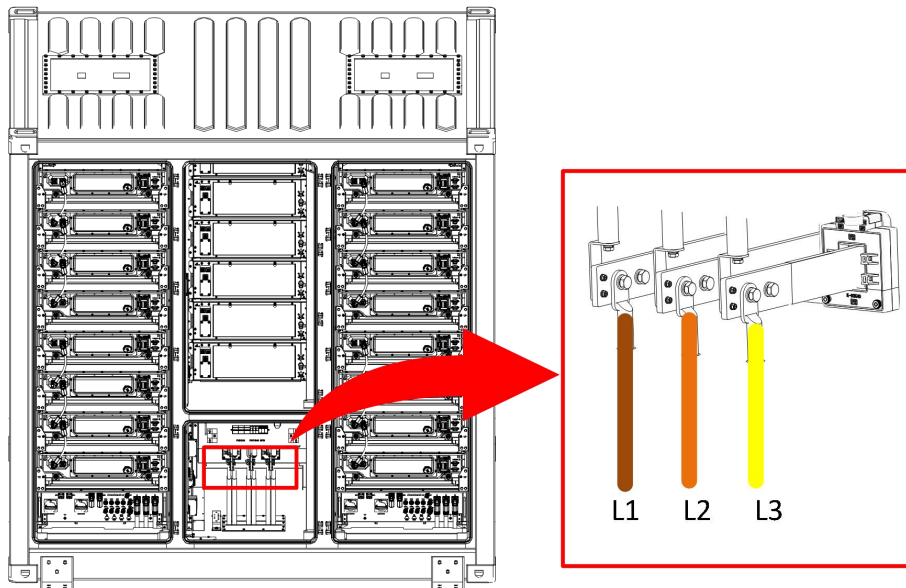

✔ Smart Matrix A (Front View)

No.	Name	Specification
1	Recommended Cable (Per Phase)	L1/L2/L3, 150mm ² (300Kcmi) Rated Voltage: AC 1000V min Rated Temperature: 105°C min
2	Connection terminal	SC150-12 (Torque: 47N·m)

5.5. Auxiliary Power Supply Cable Connection

Connect the **external auxiliary power supply (User-supplied, AC 380V±15%, Power≥30kW)** to the XTAC terminal block of the Smart Matrix A.

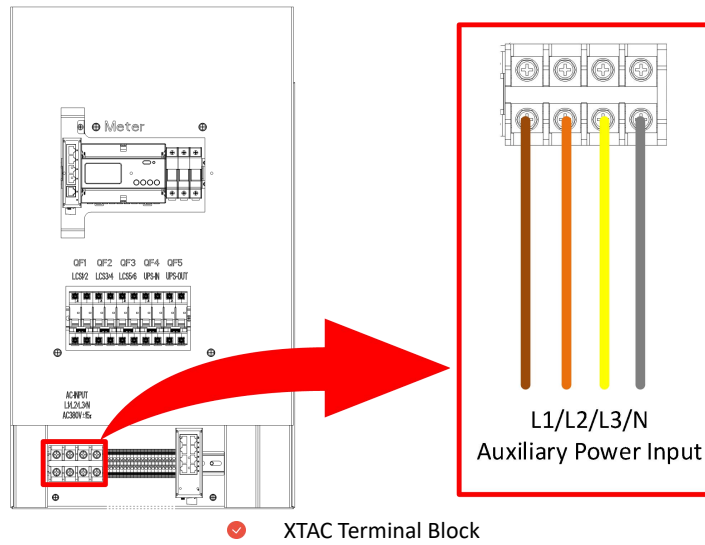

No.	Name	Specification
1	Requirement for External Auxiliary Power Supply	AC 380V±15%, Power≥30kW
2	Recommended Cable (Per Phase)	L1/L2/L3/N, 16mm ² (6AWG) Rated Voltage: 600V AC min Rated Temperature: 105°C min
3	Connection terminal	SC16-6 (Torque: 5N·m)

5.6. Communication Cable Connection (Reserved)

5.6.1. IES

The IES #1 provides connections to the external the internet, the array EMS, the host computer, as well as to multiple Smart Matrix A units in parallel.

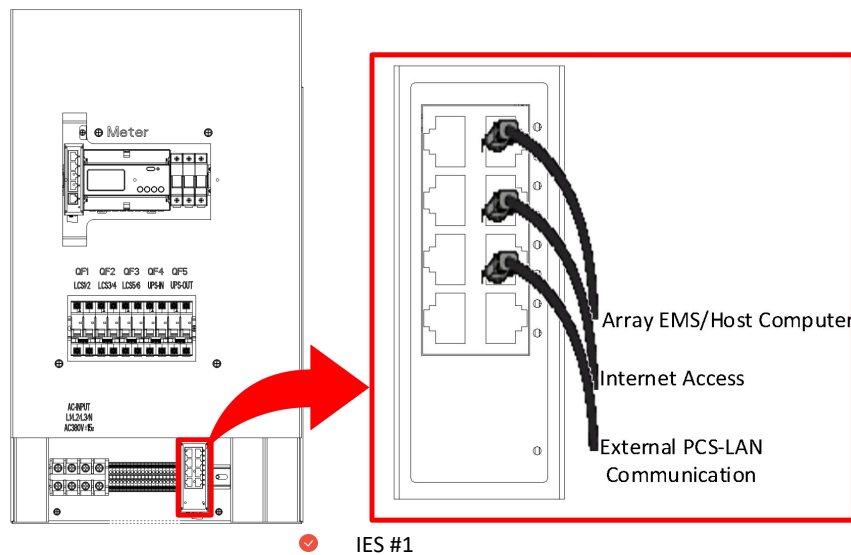

No.	Name	Specification
1	Recommended Cable	Category 5e cable
2	Connection terminal	RJ45 plugs

5.6.2. Communication Terminal block XT1

Terminal block XT1 is used for communication connections to external devices.

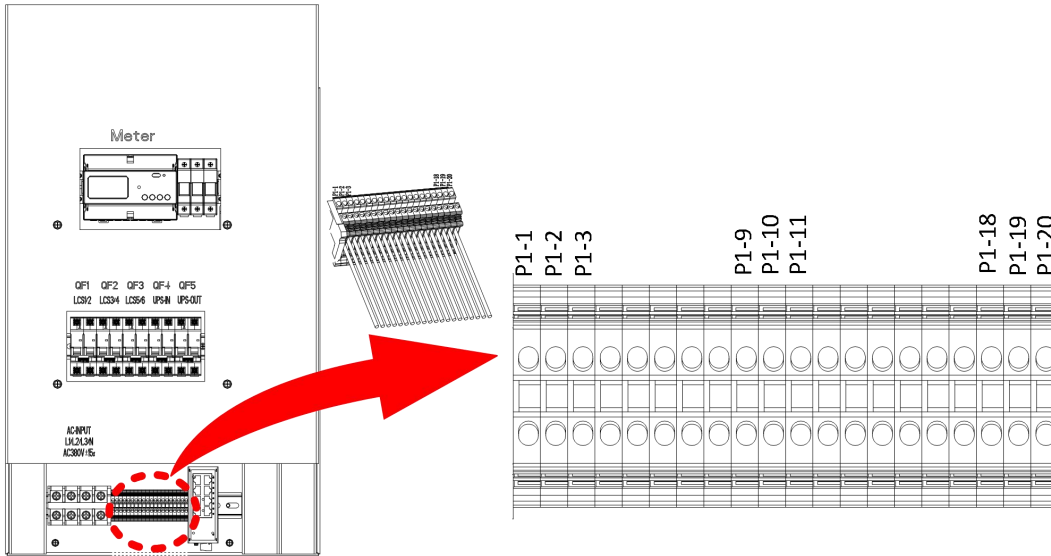

✓ XT1 Communication Terminal Block

Interface	PIN	Definition
P1-1	RS485A	TO GRID-Meter (If required)
P1-3	RS485B	
P1-2	RS485A	TO LOAD-Meter (If required)
P1-4	RS485B	
P1-5	FAULT-DO+	System Fault Signal Output (Dry Contact)
P1-6	FAULT-DO-	
P1-7	DI+	Reverse power signal input (Dry contact)
P1-8	DI-	
P1-9	STOP-DO+	External emergency stop signal input (Dry contact)
P1-10	STOP-DO-	
P1-11	FSS -OUT/DC24V+	(In a 5MWh ESS) TO Smart Matrix A#2/3-FSS-OUT/DC24V
P1-12	FSS -OUT/DC24V-	
P1-13	FSS -LINK/OUT+	(In a 5MWh ESS) TO Smart Matrix A#2-FSS-LINK/OUT
P1-14	FSS -LINK/OUT-	
P1-15	FSS -LINK/IN+	(In a 5MWh ESS) TO Smart Matrix A#3-FSS-LINK/IN
P1-16	FSS -LINK/IN-	
P1-17	FSS -A+	(In Multiple 5MWh ESS) TO the Preceding 5MWh ESS
P1-18	FSS -B+	
P1-19	FSS -A-	(In Multiple 5MWh ESS) TO the Next 5MWh ESS
P1-20	FSS -B-	

No.	Name	Specification
1	Recommended Cable	0.5mm ² (22AWG), twisted-pair shielded cable
2	Connection terminal	E0510 ring terminal (Torque: 0.6N.m)

6. Power-On/Power-Off Procedure

6.1. Check Before Power on

No.	Check items
1	The cabinet is securely installed in a well-ventilated, accessible location, ensuring easy operation, maintenance, and heat dissipation, within a clean and tidy environment.
2	All cables are correctly and firmly connected. Cable binding meets the wiring requirements, reasonable distribution and no damage.

Before power on, please check the following items carefully to ensure that they are correct:

- 1) The emergency shutdown button is in the released state.
- 2) Check to ensure there is no grounding fault.
- 3) Use the multimeter to check whether the AC side voltage meets the starting conditions and there is no overvoltage danger.
- 4) Check for short circuit in the system AC circuits.
- 5) Check to ensure that no tools or parts are left inside the equipment.

The locations of the circuit breakers, buttons, rotary switch, and indicators that may be operated during the power-on/power-off procedures are shown in the figures below.

Note
Before initially energizing the AC side, qualified personnel shall close the upstream grid switch to apply power to the energy storage cabinet's connection point. Upon energization, the voltage and frequency shall be verified to be within specified limits at that point, and the phase sequence shall be confirmed as correct using a phase sequence meter.

6.2. Power On

- 1) Manually turn the AC circuit breakers (**QF1 to 5**) to the ON position on the communication power distribution panel.
- 2) Confirm that the UPS is powered on and output.
- 3) Confirm that the EMS screen and indicator (**PWR**) on the PCS is lit.
- 4) Manually turn the AC rotary switch (**QA1,QA2**) to the ON position.
- 5) Manually turn the DC rotary switch (**DC1 SWITCH,DC2 SWITCH**) in the PCS to the ON position.
- 6) Confirm that the EMS screen shows no alarms.
- 7) Complete.

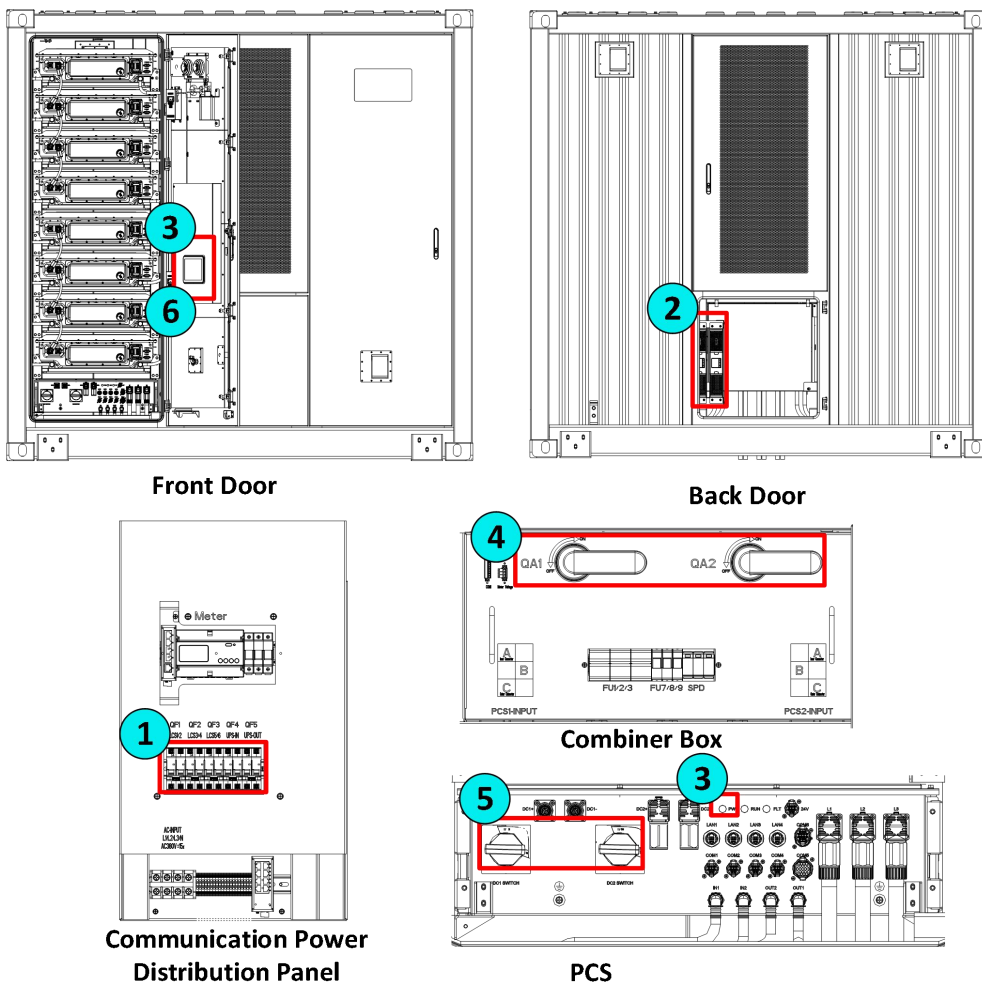

6.3. Power Off

- 1) On the EMS screen, click “POWER-OFF” to ensure the PCS shuts down. Verify that the system power/current reading is 0.
- 2) Manually turn the DC rotary switch (**DC1 SWITCH,DC2 SWITCH**) in the PCS to the OFF position.
- 3) Manually turn the AC rotary switch (**QA1,QA2**) to the OFF position.
- 4) Manually turn the AC circuit breakers (**QF1 to 5**) to the OFF position.
- 5) Manually press and hold the UPS power button until the unit shuts down.
- 6) Complete.

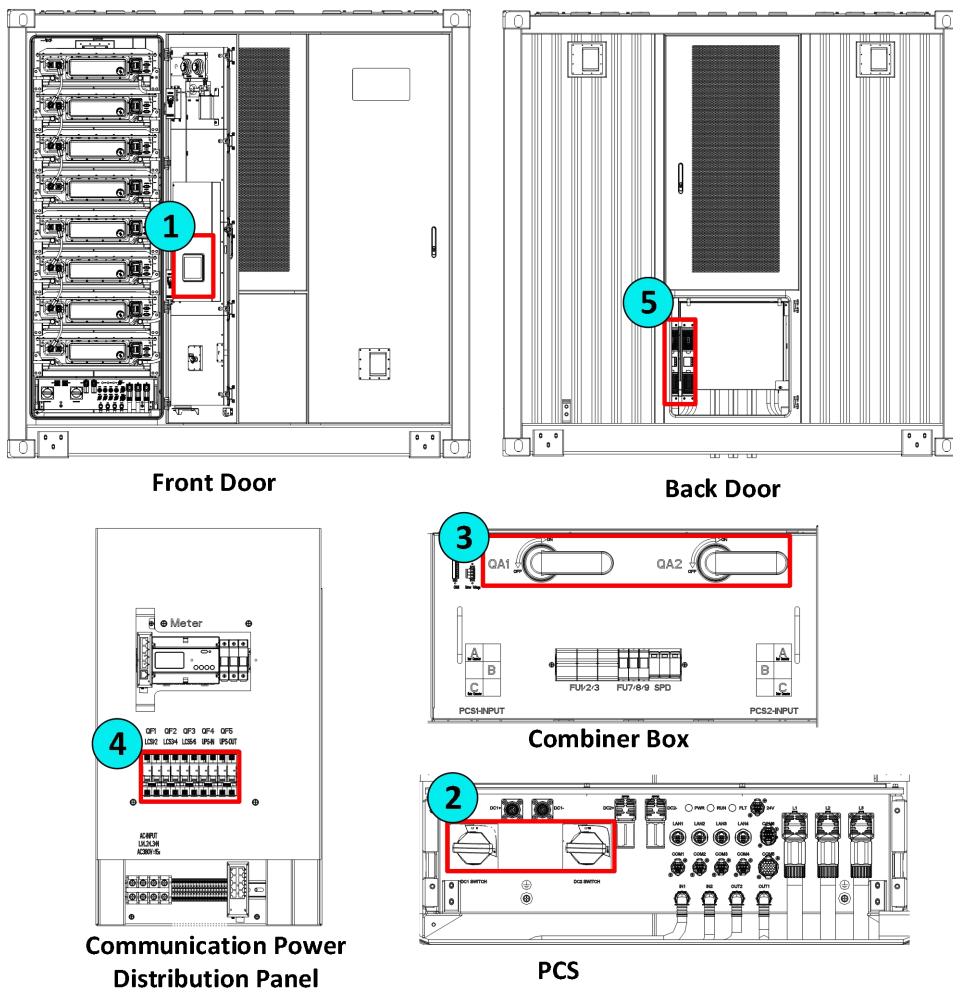

6.4. Equipment Door-close

Note

- After the energy storage system is powered on, if there is no abnormal situation, please close the equipment door.
- Close the equipment door and keep the key properly.

7. Revision Table

The document revision history is tracked in the following table:

Revision Number	Date (MM/DD/YYYY)	Description
1.0	Dec 20, 2025	Initial version



Technical Support

Email: support@renonpower.com

Renon Power USA LLC

580 McIntyre Rd. McKinney, TX 75071

Renon Power Technology B.V.

Rietbaan 10, 2908 LP Capelle aan den IJssel

Renon Power 株式会社

東京都中央区日本橋箱崎町 20-5 VORT 箱崎 5F



LinkedIn



Website